



LUKER
JV LUKER USA



PROTECT YOUR FAMILY AND HOME WITH
LUKER MCBS, RCCBS & DBS



LUKER LAUNCHING "ANTI-DUST" MCB DBS FIRST TIME IN INDIA

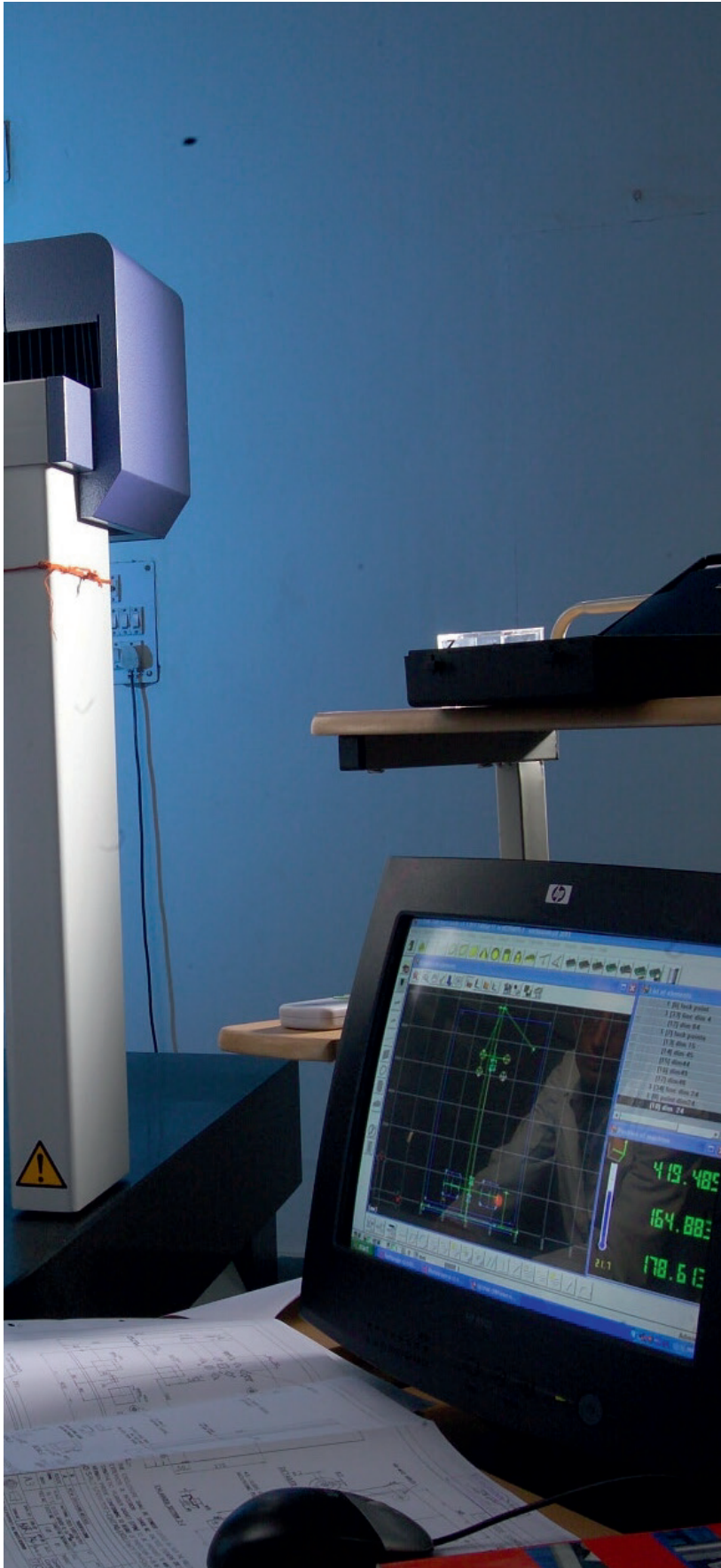

Contents

Radium R3 - Miniature Circuit Breaker	
Introduction	3
Highlights	4
Features - Construction	5
Technical Data - Characteristics	6
Technical Data - Tripping Curves	7
Product Reference	8
Product Reference - Isolator & Accessories	10
Dimensions	11
Radium R3 - Residual Current Circuit Breaker	
Introduction	12
Highlights	13
Technical Data - Characteristics	14
Features - Performance	15
Product Reference - RCCB	17
Dimensions	18
Anti-dust 3 (Ad3) - Distribution Board	
Introduction	20
Features - Performance	20
SP&N Distribution Board	21
TP&N Distribution Board	22
Manual Phase Selector Horizontal DB	23

INTRODUCTION - MCB

Radium- R3

MINIATURE CIRCUIT BREAKER

As power distribution needs play a pivotal role in all the significant sectors namely Commercial, Industrial and Residential, improved Breaker performance through better electrical safety, higher operational endurance, continued service and reduced cost have become of paramount importance. LUKER Radium R3 MCBs have been engineered to constantly fulfill the above requirements. With these features LUKER is setting new standards for user friendly and superlative electrical circuit protection.









The LUKER Radium R3 MCB is a high performing Thermal Magnetic current limiting device with the ability to disconnect short circuits up to 10kA. The range is available in tripping characteristics types C for SP, SP&N, DP, TP, TP&N & FP configurations in 0.5 - 125A current ratings.

All metal components for operating mechanism of Radium R3 circuit breaker are specially treated for high self lubrication leading to repeat accuracy during service life. The MCBs conform to Standards: IEC 60898-1995 and IS/IEC 60898-1:2002 and stand guaranteed for best quality for optimum performance.



HIGHLIGHTS

SAFE | **CONVENIENT** | **ENERGY SAVING** | **WIDE RANGE**

IP 20 Degree Protection	Terminals are finger touch proof. Prevents electrical shock by accidental touch.	
Trip Free Mechanism	MCB trips even if held in ON position.	
Padlocking Facility	Dolly can be padlocked in - OFF position for personal safety during maintenance - ON positing for extremely critical loads	
Current Limiting Design - Class 3	Minimum let through energy under fault condition due to ultra fast contact separation and rapid quenching of the arc. This reduces stress on connected loads and cables.	
High Terminal Capacity with Deep Serrations	Ensures proper termination and firm connection to accommodate 35 sq mm cable.	
Bi-connect Termination Possible	Choice to use Busbar and/or cable in the same terminal, provides reliable termination.	
Din Rail Mounting	Two stage snapping device for simple effortless and firm seating on 35 mm Din Rail, easy & efficient mounting.	
Combination Head Captive Screws	Safe and provides the flexibility of both +/- Head screw driver.	
Low Power Consumption	Cost effective and energy saving. The Watt loss of Radium R3 MCBs is extremely low providing valuable energy savings over its entire life cycle.	
Legend Plate	Ensures circuit identification and enhanced safety.	
Wide range	0.5 to 125A 1P, 1P+N, 2P, 3P, 3P+N & 4P configurations B, C & D Tripping Characteristic	
Air circulation	When two poles are placed adjacent to each other, these channels form a tunnel resulting in effective air circulation around individual poles.	
2 Position dolly	Clear indication of the operational status of device.	

FEATURES - CONSTRUCTION

HOUSING

Radium R3 MCBs are made up of engineered thermo plastic for self lubrication and critical performance. The housing and other moulded components are fire retardant having high melting point, low water absorption and high dielectric strength therefore enabling it to withstand high temperature.

OPERATING MECHANISM

Radium R3 Circuit Breakers are based on Thermal Magnetic technology. The protection is ensured by combining a temperature receptive mechanism (bimetal) and a current sensitive electro-magnetic device. The thermal operation provides protection from normal overload and the electro-magnetic device against large overloads and short circuits.

SUPERIOR CONTACT MECHANISM

The mechanism comprises of fixed and moving contacts made up of silver graphite for surety, extended life span and anti-weld properties. These contacts have low contact resistance resulting in reduced voltage drop and low watt loss commensurating to energy savings.

HIGH TECH ARC BLOWER

Protects from hazards of overloads and short-circuits. The arc under the influence of magnetic field is moved into the arc chute where it is quickly extinguished and quenched.

MAXIMUM BACKUP PROTECTION

To protect the Radium R3 circuit breakers against higher short circuit current, fuses should be installed at the incoming side. The current rating of these fuse links should not be more than the values stated in the table.

MCB RATING	BACK-UP FUSE RATING
1A	25A
4A	50A
6A	80A
10A	100A
63A	100A

LEGEND PLATE

Easy identification of circuits irrespective of position on the Distribution Board. Very useful during maintenance. A unique feature.

WATT LOSS

RATING (AMP)	AS PER IS/IEC60898-1:2002 MAXIMUM WATT LOSS	MAXIMUM WATT LOSS IN SP
6	3.0W	0.76W
10	3.0W	1.83W
16	3.5W	2.44W
20	4.5W	3.07W
25	4.5W	2.80W
32	6.0W	3.92W
40	7.5W	3.96W
63	13.0W	6.06W

TECHNICAL DATA - CHARACTERISTICS

MCB - AC	RADIUM R3 MCB			RADIUM R3 ISOLATOR
Standard Conformity	IS/IEC60898-1-2002			IS/IEC60947-3
Type	B	C	D	
Rated Current (In)	6-63A	0.5-125A	0.5-63A	25-125A
Rated Voltage AC (Ue)	240/415V			240/415V
Utilization Category				AC22A
Rated Frequency Hz	50/60Hz			50Hz
No. of Poles (Execution)	SP, SP&N, DP, TP, TP&N & FP			SP, DP, TP & FP
Rated Short Circuit Breaking Capacity	10kA	10kA	10kA	
Rated Insulation Voltage (Ui)	660V			660V
Magnetic Release Setting	(3-5)In	(5-10)In	(10-20)In	
Rated Impulse Voltage (Uimp)	4kV			6kV
Electrical/Mechanical Life				
<32A	30,000			30,000
>32A	10,000			10,000
Ambient Temperature	-5°C to +55°C			-5°C to +55°C
Energy Limiting Class	ELC 3			
Mounting	Clip on Din rail (35 mm x 7.5 mm)			
Line Terminal Capacity	35 mm ²			35 mm ²
Degree of Protection	IP 20			IP 20
Resistance to Shock	40mm free fall			40mm free fall
Ambient reference temperature	30°C			
Installation Position	Vertical/Horizontal			Vertical/Horizontal

MCB - DC

Circuit Breakers for DC application are engineered to fulfill tough arc quenching conditions. DC MCB incorporates built in magnet to direct the arc into the arc quenching chamber.

SPECIFICATIONS

Standard Conformity	IEC 60898-2
Current Rating	0.5-63A
No. of Poles	SP & DP
Voltage Rating	220V (max.)
Short Circuit Breaking Capacity	10kA

TECHNICAL DATA - TRIPPING CURVES

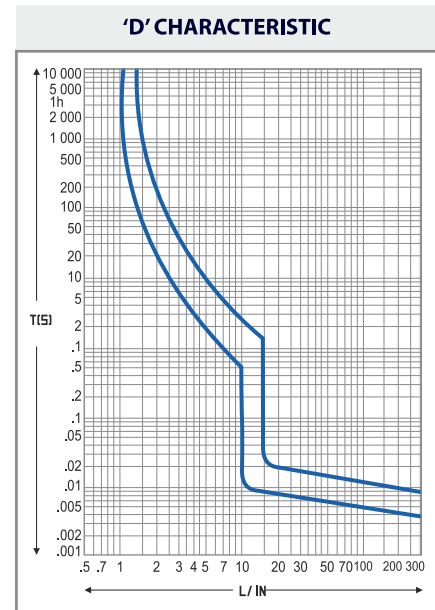
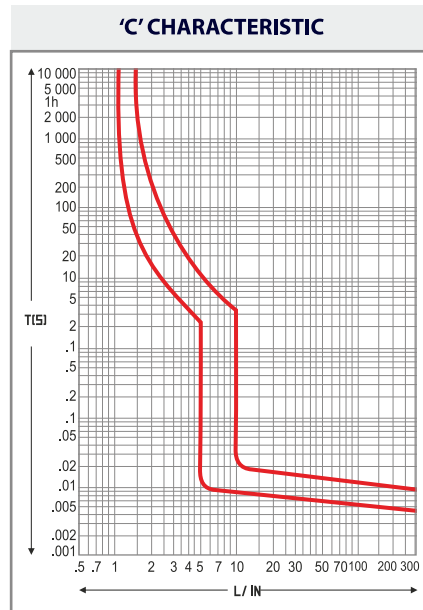
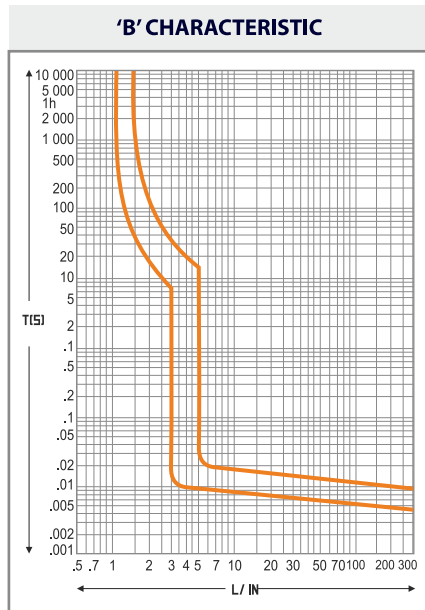

TYPE	APPLICATION	THERMAL TEST CURRENT		TRIPPING TIME IN≤63A	ELECTRO MAGNETIC TEST CURRENT	TRIPPING TIME (T)
		LOW	HIGH			
2	Lighting & Distribution with no surge Current	1.13xIn		>1hour	3xIn	>0.1s
			1.45xIn	<1hour	3xIn	<0.1s
6	Inductive Load with surge Current	1.13xIn		>1hour	5xIn	≥0.1s
			1.45xIn	>1hour	5xIn	<0.1s
10	High Inductive Load & High Inrush Current	1.13xIn		<1hour	10xIn	≥0.1s
			1.45xIn	>1hour	20xIn	<0.1s

TEMPERATURE DERATING

In plant engineering situations, where ambient temperature is higher than the regulatory reference temperature of 30°C, the circuit breakers may be subjected to untimely tripping, i.e. opening when not required, since the increase in temperature is interpreted as a current surge. Ambient temperature, as a matter of fact, affects the initial deformation of the bimetal. At a temperature above 30°C the thermal release trips faster, behaving like a relay with a lower nominal current. It is therefore imperative to take into account nominal current derating if the circuit breaker is installed in an ambient temperature above 30°C.

The table gives the max. operating current referring to the different temperatures.

In(A)	TEMPERATURE					
	25°C	30°C	35°C	40°C	45°C	50°C
2	2.04	2	1.96	1.9	1.86	1.82
6	6.24	6	5.82	5.52	5.28	4.98
10	10.40	10	9.7	9.2	8.8	8.3
16	16.5	16	15.5	15	14.4	14.1
20	20.6	20	19.4	18.8	18	17.1
25	25.8	25	24.3	23.5	22.5	22
32	33	32	31.04	30.1	28.8	28.2
40	41.2	40	38.8	37.6	36	35.2
63	64.89	63	61.79	60	58	56.07

PRODUCT REFERENCE



Single Pole

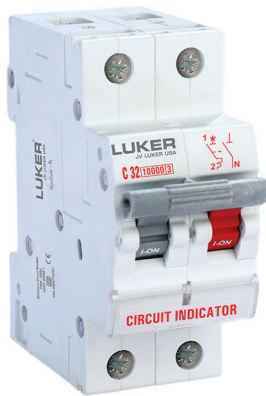

Single Pole
+
Neutral

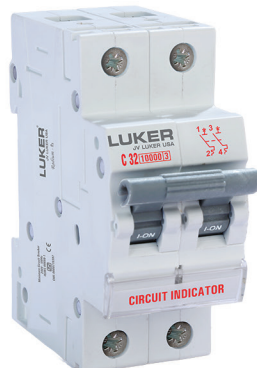

Double Pole



Description	In(A)	Reference
		'C' Curve R3
Single Pole	0.5	LDMC00SPC00P5
	1	LDMC00SPC0001
	2	LDMC00SPC0002
	3	LDMC00SPC0003
	4	LDMC00SPC0004
	5	LDMC00SPC0005
	6	LDMC00SPC0006
	10	LDMC00SPC0010
	16	LDMC00SPC0016
	20	LDMC00SPC0020
	25	LDMC00SPC0025
	32	LDMC00SPC0032
	40	LDMC00SPC0040
	50	LDMC00SPC0050
	63	LDMC00SPC0063
80	LDMC00SPC0080	
100	LDMC00SPC0100	
125	LDMC00SPC0125	
Single Pole + Neutral	0.5	LDMC0SPNC00P5
	1	LDMC0SPNC0001
	2	LDMC0SPNC0002
	3	LDMC0SPNC0003
	4	LDMC0SPNC0004
	5	LDMC0SPNC0005
	6	LDMC0SPNC0006
	10	LDMC0SPNC0010
	16	LDMC0SPNC0016
	20	LDMC0SPNC0020
25	LDMC0SPNC0025	
32	LDMC0SPNC0032	
40	LDMC0SPNC0040	
50	LDMC0SPNC0050	
63	LDMC0SPNC0063	
Double Pole	0.5	LDMC00DPC00P5
	1	LDMC00DPC0001
	2	LDMC00DPC0002
	3	LDMC00DPC0003
	4	LDMC00DPC0004
	5	LDMC00DPC0005
	6	LDMC00DPC0006
	10	LDMC00DPC0010
	16	LDMC00DPC0016
	20	LDMC00DPC0020
	25	LDMC00DPC0025
	32	LDMC00DPC0032
	40	LDMC00DPC0040
	50	LDMC00DPC0050
	63	LDMC00DPC0063
	80	LDMC00DPC0080
	100	LDMC00DPC0100
	125	LDMC00DPC0125

PRODUCT REFERENCE



Three Pole

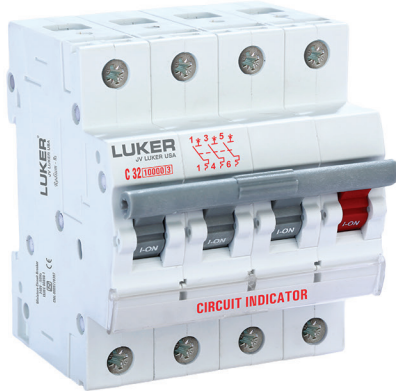

Three Pole + Neutral

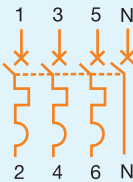

Four Pole

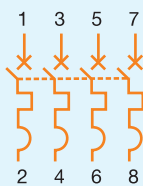

Description	In(A)	Reference
		'C' Curve
Three Pole	0.5	LDMC00TPC00P5
	1	LDMC00TPC0001
	2	LDMC00TPC0002
	3	LDMC00TPC0003
	4	LDMC00TPC0004
	5	LDMC00TPC0005
	6	LDMC00TPC0006
	10	LDMC00TPC0010
	16	LDMC00TPC0016
	20	LDMC00TPC0020
	25	LDMC00TPC0025
	32	LDMC00TPC0032
	40	LDMC00TPC0040
	50	LDMC00TPC0050
63	LDMC00TPC0063	
80	LDMC00TPC0080	
100	LDMC00TPC0100	
125	LDMC00TPC0125	
Three Pole + Neutral	0.5	LDMC0TPNC00P5
	1	LDMC0TPNC0001
	2	LDMC0TPNC0002
	3	LDMC0TPNC0003
	4	LDMC0TPNC0004
	5	LDMC0TPNC0005
	6	LDMC0TPNC0006
	10	LDMC0TPNC0010
	16	LDMC0TPNC0016
	20	LDMC0TPNC0020
	25	LDMC0TPNC0025
	32	LDMC0TPNC0032
	40	LDMC0TPNC0040
	50	LDMC0TPNC0050
63	LDMC0TPNC0063	
Four Pole	0.5	LDMC00FPC00P5
	1	LDMC00FPC0001
	2	LDMC00FPC0002
	3	LDMC00FPC0003
	4	LDMC00FPC0004
	5	LDMC00FPC0005
	6	LDMC00FPC0006
	10	LDMC00FPC0010
	16	LDMC00FPC0016
	20	LDMC00FPC0020
	25	LDMC00FPC0025
	32	LDMC00FPC0032
	40	LDMC00FPC0040
	50	LDMC00FPC0050
	63	LDMC00FPC0063
	80	LDMC00FPC0080
	100	LDMC00FPC0100
125	LDMC00FPC0125	

PRODUCT REFERENCE - ISOLATOR & ACCESSORIES

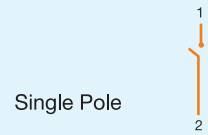

In(A)	Reference
25	LDSD000SP0025
40	LDSD000SP0040
63	LDSD000SP0063
80	LDSD000SP0080
100	LDSD000SP0100
125	LDSD000SP0125

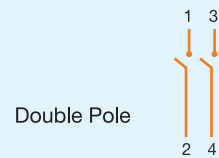

25	LDSD000DP0025
40	LDSD000DP0040
63	LDSD000DP0063
80	LDSD000DP0080
100	LDSD000DP0100
125	LDSD000DP0125

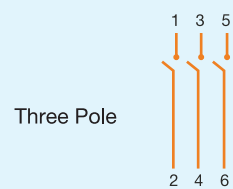

25	LDSD000TP0025
40	LDSD000TP0040
63	LDSD000TP0063
80	LDSD000TP0080
100	LDSD000TP0100
125	LDSD000TP0125

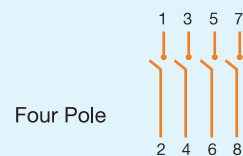

25	LDSD000FP0025
40	LDSD000FP0040
63	LDSD000FP0063
80	LDSD000FP0080
100	LDSD000FP0100
125	LDSD000FP0125

DIMENSIONS

INSTALLATION DIMENSIONS - MCB (.05 TO 63A) / ISOLATOR (25 TO 63A)

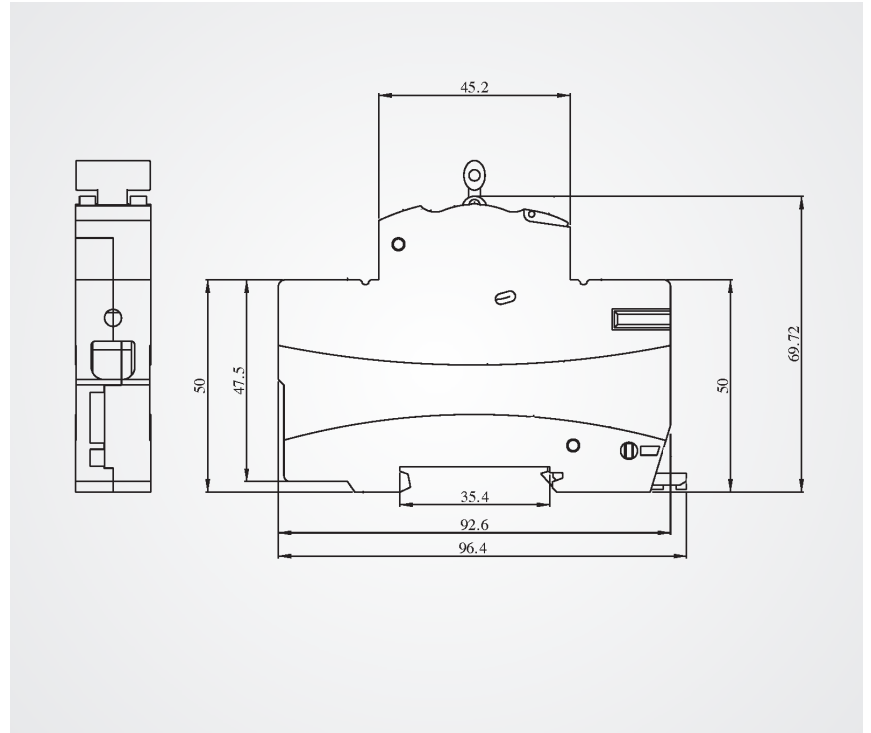
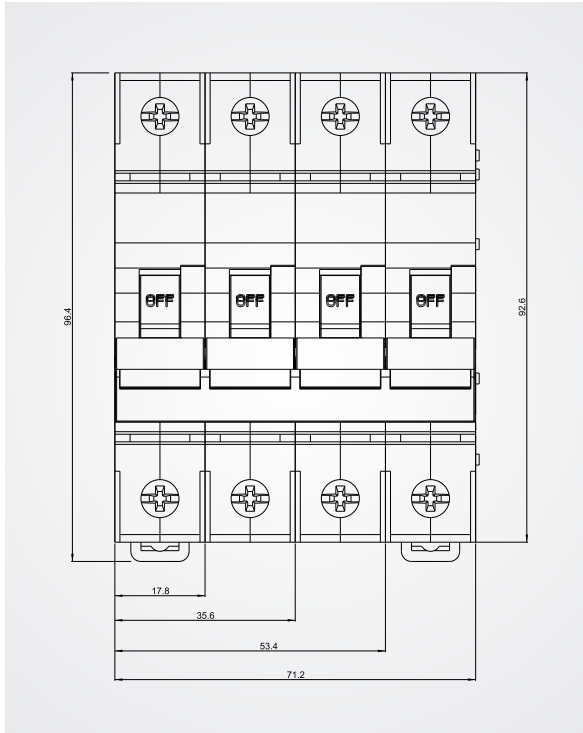

INSTALLATION DIMENSIONS MCB (80 TO 125A)

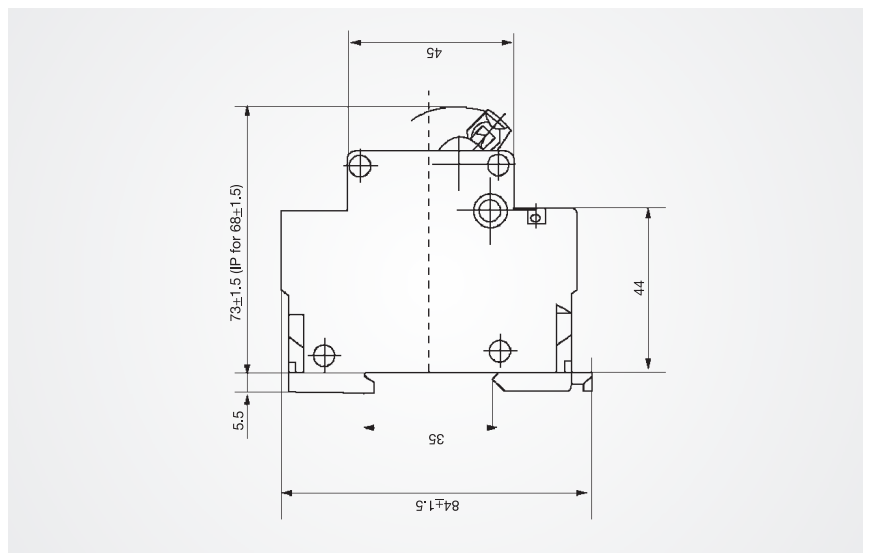
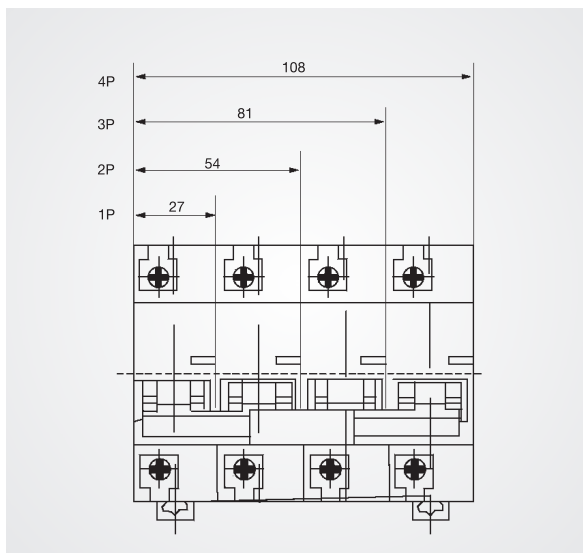

INTRODUCTION - RCCB

Radium- R3

RESIDUAL CURRENT CIRCUIT BREAKER

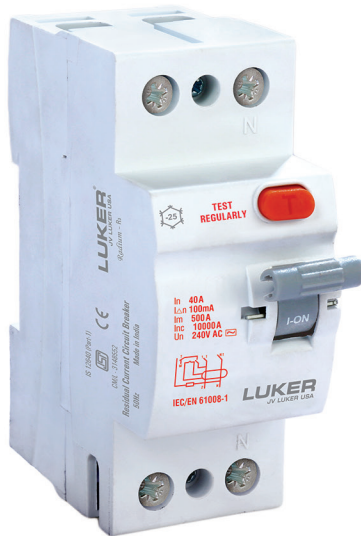

From Bungalows to High Risers, from Trade Centres to Hotels, from Clinics to Hospitals, from escalators to elevators electricity is the foremost requirement. Electricity has become an integral part of our life so common to our daily requirements that we forget its intricacies and hazardous behaviour.





Day after day we come across many un to do events hampering human lives due to negligent usage of electricity. Even large number of Industrial and Domestic fire are attributed to and caused by electricity.

Faulty insulated equipments or wrong usage of electrical devices cause current to flow through insulation to the earth. This is leakage current. This current poses two severe risk factors which are

- Fire Risk
- Electrocutation Risk

Residual Current Circuit Breaker provides the function of isolation switching and earth leakage protection of electrical circuits. It also provides the indirect protection of the human body against the dangerous effects of electric current. It is also a protective device against fire caused by the electrical circuit fault.

PHYSIOLOGICAL EFFECT OF ELECTRIC CURRENT ON HUMAN BODY

500 mA		Immediate cardiac arrest resulting in death
70-100 mA		Cardiac fibrillation; the heart begins to vibrate and and no longer beats at a steady rate. This situation is dangerous since it is irreversible
20-30 mA		Muscle contraction can cause respiratory paralysis
10 mA		Muscle contraction: the person remains "stuck" to the conductor
1-10 mA		Prickling sensations

As per Indian Electricity Rules 1956 at all installations with load above 5 KW use of RCCB is compulsory

HIGHLIGHTS

A state-of-the-art product fit for Industrial, Residential and Commercial applications. It is one piece residual current circuit breaker which is used both for control and isolation of electrical circuits. It provides total protection to all living beings against direct and indirect contact as well as to installations, big or small, against insulation faults. **Human life is valueless and Radium R3 RCCB is the solution provider for safeguarding it.**

Majority of mishaps occur due to current leakage consequently leading to fire. Radium R3 RCCB of the required rating instantly detects this leakage and terminates the supply reducing the risk of any kind of fire. The range is available in AC Residual Tripping Characteristics in 2 & 4 Pole configurations in 10, 16, 20, 25, 32, 40, 63, 80 & 100Amps in 30, 100 & 300mA sensitivity.

- Provides protection against earth fault/leakage current and also fulfill the function of isolation.
- Automatically measures and disconnect the circuit when earth fault/leakage current occurs and exceeds the rated sensitivity.
- High short-circuit current withstand capacity - 10kA
- Dual termination possible for cable and comb type busbar connection
- Equipped with finger protected connection terminals (IP20)
- Fire resistant plastic parts to withstand abnormal heating and strong impact
- Independent of power supply and line voltage. Also free from external voltage fluctuation.
- Incorporates a filtering device for prevention of nuisance tripping due to transient voltage
- Easy padlocking facility.



TECHNICAL DATA - CHARACTERISTICS

Standards			IS 12640-1:2008
Residual tripping characteristics			AC
Tripping time at $I\Delta n$	Instantaneous	ms	<40
	Selective	ms	>150
Rated current		A	10, 16, 20, 25, 32, 40, 63, 80 & 100
Rated residual current $I\Delta n$		mA	30, 100, 300
Calibration temperature		°C	30
Number of poles versus modules			1
Rated voltage U_n	2P AC	V	240
	4P AC	V	415
Frequency		Hz	50/60
Maximum service voltage U_{bmax}		V	2P=265 / 4P=455
Minimum service voltage U_{bmin}		V	2P=100 / 4P=190
Power supply			Top / Bottom
Rated making and breaking capacity (Im)		A	500 (or 10xIn)
Residual making and breaking capacity (I Δ n)		A	500 (or 10xIn)
Conditional short-circuit capacity (Inc)		A	6000 Fuse 100A gLgG
Conditional residual short-circuit capacity (I Δ n)		A	6000 Fuse 100A gLgG
Grid distance (safety distance between two devices)		mm	35
Isolator application			yes
Insulation degree	Insulation voltage	D	660
	Shock voltage (1.2/50 μ s)	kV	6
	Insulation resistance	m Ω	1000
	Dielectric strength	V	2500
Shock resistance (in x, y, z direction) (EN / IEC 60077/16.3)		40g	18 shocks 5 ms
Vibration resistance (in x, y, z direction; EN / IEC 60068-2-6)		1.5g	30 min, 0~80Hz
Endurance	electrical at U_n, I_n		10000
	mechanical at U_n, I_n		20000
Protection degree (outside/inside electrical enclosure) with door			IP20 / IP40
Self extinguish degree (according to UI94)			V2
Tropicalisation (acc. to EN/IEC 60068-2, DIN 40046)		°C/RH	+55 / 95%
Pollution degree (acc. EN/IEC 60947-1)			3
Operating temperature			AC (-5 ~ +60)
Storage temperature		°C	-25~+70
Terminals capacity	Rigid cable min/max (top)	mm ²	1.5/25
	Flexible cable min*/max (top)	mm ²	1.5/25
	Rigid cable min/max (bottom)	mm ²	1.5/25
	Flexible cable min*/max (bottom)	mm ²	1.5/25
	(*Flexible cable 0.75/1/1.5 mm ² with cable lug)		
Busbars systems	Pin		yes
	Fork		yes
CE marking			yes
Torque	Top / Bottom	Nm	5/5

FEATURES - PERFORMANCE



Test Button



Rated current I_n / $I_{\Delta n}$



DIN Rail Mounting

TYPE AC		
Rated Current setting I_n	A	10, 16, 20, 25, 32, 40, 63, 80, 100
Residual current $I_{\Delta n}$	mA	30, 100, 300
Rated voltage AC U_n	V	2P : 240; 4P : 415
Minimum operating voltage U_{bmin}	V	2P : 100; 4P : 190
Mechanical/electrical endurance		20000 / 10000
Tropicalisation acc.to		
EN/IEC 60068-2-28/2-30 and DIN 40046		95% RH at 55 °C
Terminal capacity flexible/rigid cable	mm ²	25/25
Poles		DP, FP
Nuisance tripping resistance		250A 8/20us; 200A 0.5us - 100kHz
Ambient temperature	°C	-5 upto 40
Weight	g	2P- 224.5; 4P-409

SHORT-CIRCUIT CAPACITY	
Acc. to EN/IEC 61008-1	$I_m = 500A$
Making and breaking capacity	$I_{Dm} > 500A$ from 16 upto 40A $I_{Dm} = 10I_n$ from 63 upto 100A
Short-circuit capacity	$I_{nc} = 10000A$ at 240/415V Fuse 80A gG

NORMAL OPERATION AND MOUNTING REQUIREMENT

1. Ambient temperature $-5^{\circ}C \sim +40^{\circ}C$ •Altitude above sea level less than 2000 m.
2. Humidity not exceeding 50% at $40^{\circ}C$ and not exceeding 90% at $25^{\circ}C$.
3. Installation class II or III.
4. Pollution degree 3.
5. All equipments used should be properly earthed.
6. For right operation should ensure that the neutral conductor on the load side of the RCCB must not be linked to earth. Otherwise tripping may be impaired or nuisance tripping may occur.
7. Installation method DIN Rail mounting type.
8. Product should be installed vertically at the place where there shall be no severe impact and vibration.
9. The product is switched on when the handle is at upper position.

RCCB TRIPPING CAUSE DETECTION & REMEDY

1. Switch OFF all the MCBs connected to the circuit downstream the RCCB.
2. Switch ON the RCCB and switch ON the MCBs one by one.
3. During switching ON of a particular circuit RCCB keeps tripping frequently.
4. In this circuit the fault persists.
5. Isolate the faulty circuit, correct the fault. Now the RCCB will not trip.

FEATURES - PERFORMANCE

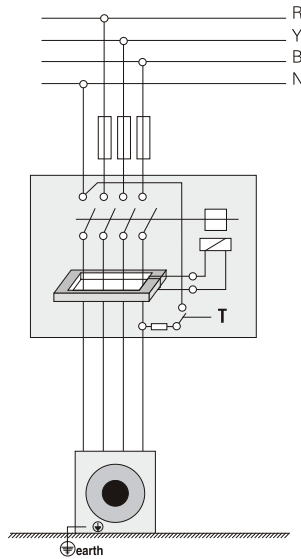

WORKING PRINCIPLE

The RCCB works on the current balance principle. The supply conductors are passed through a toroid and form the primary windings of a current transformer. Its secondary winding is connected to a highly sensitive electromagnetic trip relay, which operates the trip mechanism.

In a healthy circuit, sum of the current in phases, is equal to the current in the neutral and the vector sum of all current is equal to zero. If there is any insulation fault in the current and leakage current flows to earth, the current do not balance and their vector sum is not equal to zero. This imbalance is detected by the core balanced current transformer, the RCCB is tripped and supply to load is interrupted.

SENSITIVITY SELECTION CRITERIA

SENSITIVITY	APPLICATION
30mA	Designed for additional protection against direct contact. The 30 mA RCCB protects against leakage currents and indirect contact with earth loop impedance up to 1667 Ohms.
100mA	Is suitable for protection against indirect contact and leakage current for larger installations. The 100 mA RCCB's operate within 30 ms, but do not provide the same level of personal protection as the 30 mA units. The 100 mA RCCB protects against leakage currents and indirect contact with earth loop impedance up to 500 ohms.
300mA	A less sensitive protection device suitable for large installations having high levels of leakage current. 300 mA RCCB's protect against leakage current and indirect contact up to 167 ohms earth loop impedance.

Current Limiting Curve

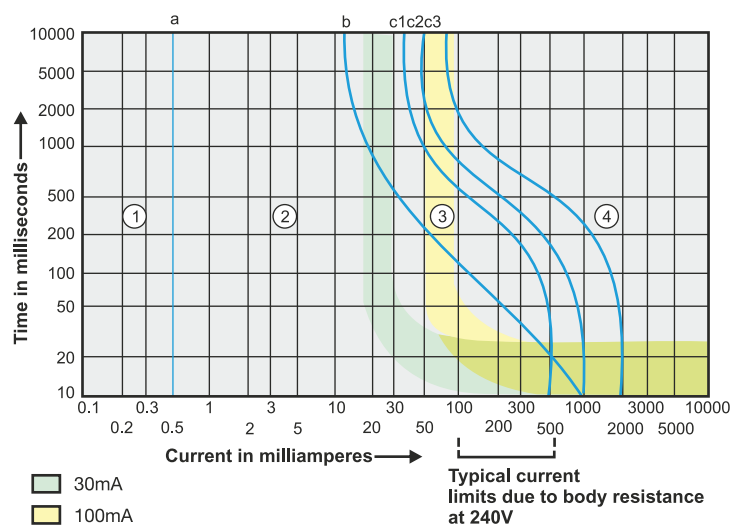

PRODUCT REFERENCE - RCCB

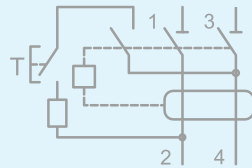
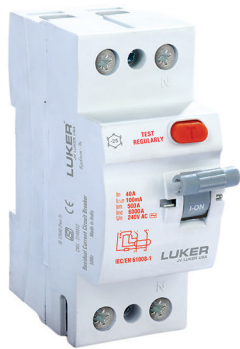

Double Pole

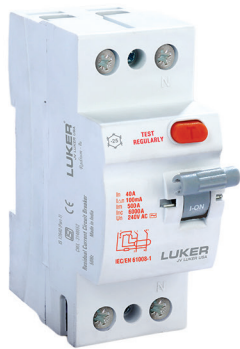
Description		Reference	Sensitivity
	10	LDRCDP10A030	30
		LDRCDP10A100	100
		LDRCDP10A300	300
	16	LDRCDP16A030	30
		LDRCDP16A100	100
		LDRCDP16A300	300
	20	LDRCDP20A030	30
		LDRCDP20A100	100
		LDRCDP20A300	300
	25	LDRCDP25A030	30
		LDRCDP25A100	100
		LDRCDP25A300	300
32	LDRCDP32A030	30	
	LDRCDP32A100	100	
	LDRCDP32A300	300	
40	LDRCDP40A030	30	
	LDRCDP40A100	100	
	LDRCDP40A300	300	
63	LDRCDP63A030	30	
	LDRCDP63A100	100	
	LDRCDP63A300	300	
80	LDRCDP80A030	30	
	LDRCDP80A100	100	
	LDRCDP80A300	300	
100	LDRCFP100A030	30	
	LDRCFP100A100	100	
	LDRCFP100A300	300	

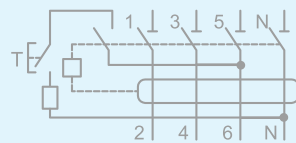

Four Pole

	10	LDRCOFP10A030	30
		LDRCOFP10A100	100
		LDRCOFP10A300	300
	16	LDRCOFP16A030	30
		LDRCOFP16A100	100
		LDRCOFP16A300	300
	20	LDRCOFP20A030	30
		LDRCOFP20A100	100
		LDRCOFP20A300	300
	25	LDRCOFP25A030	30
		LDRCOFP25A100	100
		LDRCOFP25A300	300
32	LDRCOFP32A030	30	
	LDRCOFP32A100	100	
	LDRCOFP32A300	300	
40	LDRCOFP40A030	30	
	LDRCOFP40A100	100	
	LDRCOFP40A300	300	
63	LDRCOFP63A030	30	
	LDRCOFP63A100	100	
	LDRCOFP63A300	300	
80	LDRCOFP80A030	30	
	LDRCOFP80A100	100	
	LDRCOFP80A300	300	
	LDRCFP100A030	30	
	LDRCFP100A100	100	
	LDRCFP100A300	300	

DIMENSIONS

Double Pole

LDRC0DP10A030
LDRC0DP10A100
LDRC0DP10A300

LDRC0DP40A030
LDRC0DP40A100
LDRC0DP40A300

LDRC0DP16A030
LDRC0DP16A100
LDRC0DP16A300

LDRC0DP63A030
LDRC0DP63A100
LDRC0DP63A300

LDRC0DP20A030
LDRC0DP20A100
LDRC0DP20A300

LDRC0DP80A030
LDRC0DP80A100
LDRC0DP80A300

LDRC0DP25A030
LDRC0DP25A100
LDRC0DP25A300

LDRCFP100A030
LDRCFP100A100
LDRCFP100A300

LDRC0DP32A030
LDRC0DP32A100
LDRC0DP32A300

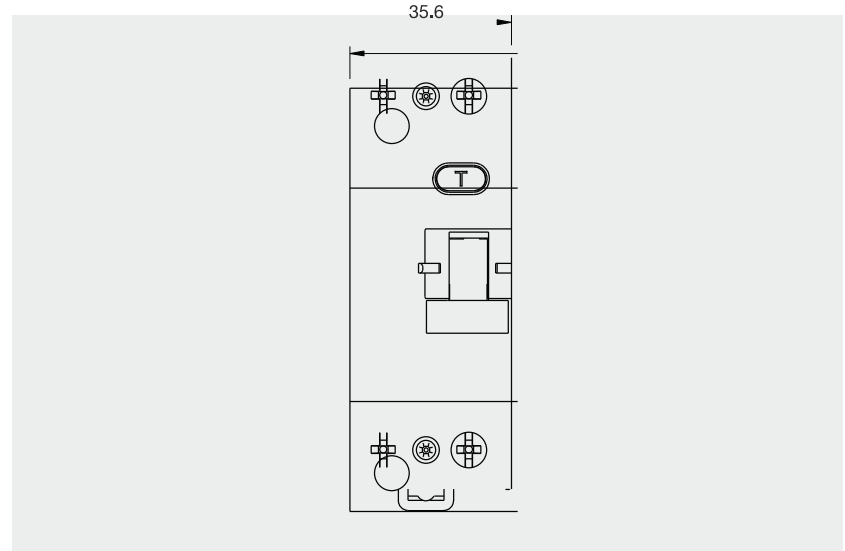

Four Pole

LDRC0FP10A030
LDRC0FP10A100
LDRC0FP10A300

LDRC0FP40A030
LDRC0FP40A100
LDRC0FP40A300

LDRC0FP16A030
LDRC0FP16A100
LDRC0FP16A300

LDRC0FP63A030
LDRC0FP63A100
LDRC0FP63A300

LDRC0FP20A030
LDRC0FP20A100
LDRC0FP20A300

LDRC0FP80A030
LDRC0FP80A100
LDRC0FP80A300

LDRC0FP25A030
LDRC0FP25A100
LDRC0FP25A300

LDRCFP100A030
LDRCFP100A100
LDRCFP100A300

LDRC0FP32A030
LDRC0FP32A100
LDRC0FP32A300

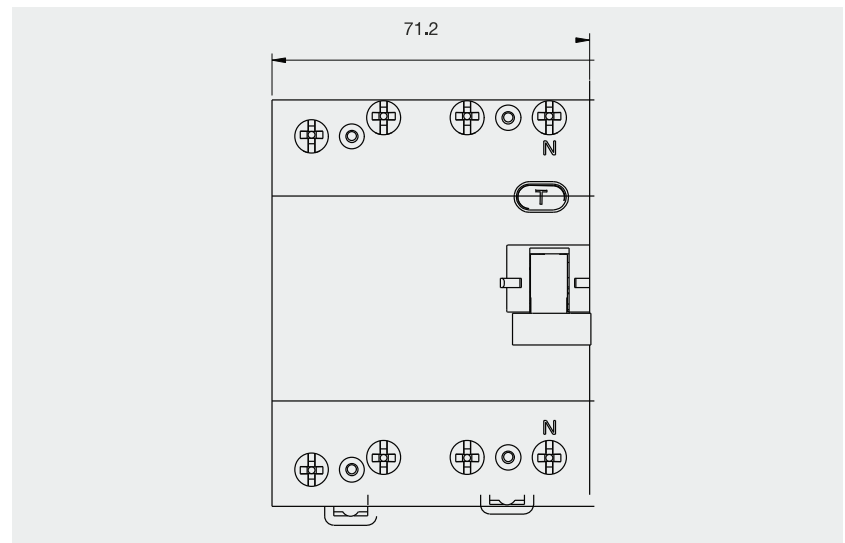

Side view - Double & Four Pole

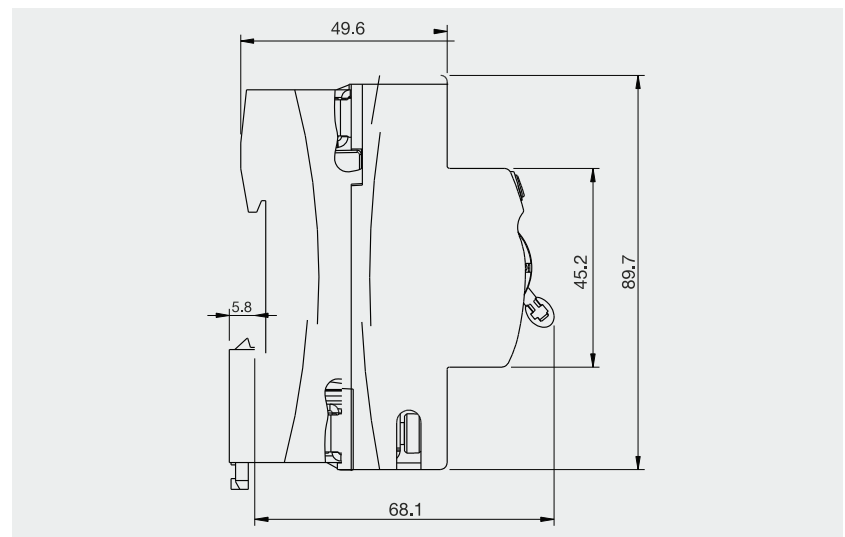

All dimensions are in mm

NO MORE DUSTING...



USE “ANTI-DUST” MCB DBS FROM LUKER



**PROTECT YOUR FAMILY AND HOME WITH
LUKER MCBS, RCCBS & DBS**



INTRODUCTION - DB

ANTI-DUST 3 (AD3)

DISTRIBUTION BOARD

The Board design is specially engineered for meeting the requirements of all the segments namely industrial, commercial and residential.

For effective and safe power distribution/sub distribution, insulated neutral links, insulated copper bus bar, earth bar and inter connecting links with lugs are part of the unit. These Boards are equipped with top and bottom removable gland plates with adequate number of knock outs, which enable easy installation and connection of conduits of all sizes. Double door construction of Distribution Boards enables easy removal and reversal of the door by just unscrewing 4 screw. These boards are a comprehensive system in itself.

The Boards are backed by the technological expertise of LUKER which excels globally in all low voltage products. The boards are of universal type, which means they can be both flush or wall mounted based on the requirement. These Distribution Boards undergo a seven tank phosphating process to ensure an anti rust conditioning, superior finish and long lasting strength. 60 micron premium quality powder coating is applied for extra smooth finish.

In addition to complying with all necessary minute technical parameters, LUKER anti-dust (AD3) Distribution Boards are highly user friendly and aesthetically par excellence. Double Door DBs meet all the requirements of IP 42/43.

FEATURES - PERFORMANCE

- Door frame assembly can be detached from the DB and it can be fixed later at our convenience
- Door frame reversibility
- Door frame reversibility is achieved by simply rotating the frame 180 degree
- Even without door frame assembly line supply can be given with adequate safety
- Anti-dust coating over the powder coating prevents accumulation of dust. It also act as a paint protector which ensures longer life
- Because of Anti-dust coating better corrosion resistance than normal conventional coating
- Door earthing is done with properly crimped wire to ensure adequate safety
- Generous wiring space with minimum partition
- Bus bar for rotary switch is insulated with electrical grade sheet shrinkable sleeves for required electrical safety
- Crimped pin type socket with crimped wires are provided for better continuity with less stress in the electrical system



- Easy removable incoming and rotary sheet cover independently without depending on other
- Aesthetically superior Distribution Boards to suit the style of your interior decor.
- 3 Piece Concept for ease of maintenance - where instead of removing door assembly (Inner & Outer) only the intermediate plate needs to be removed for the purpose of maintenance, without spoiling the alignment & associated plastering / paint work.

SP&N DISTRIBUTION BOARD

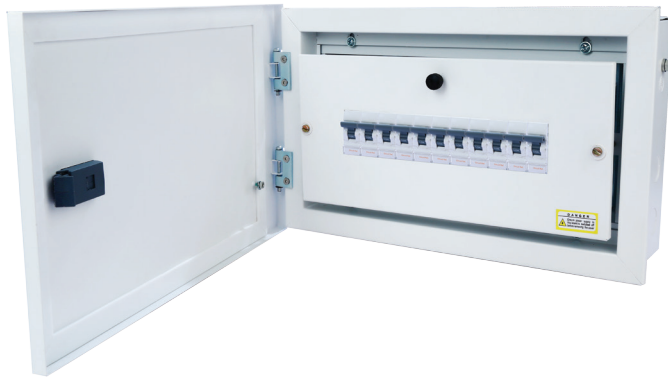

NO. OF WAYS	I/C+O/G	CAT NO. (DD)
4	4	Lddb00SPN004WDD
6	6	Lddb00SPN006WDD
8	8	Lddb00SPN008WDD
12	12	Lddb00SPN012WDD
16	16	Lddb00SPN016WDD

DIMENSIONS

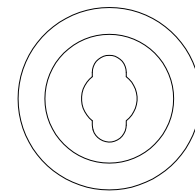
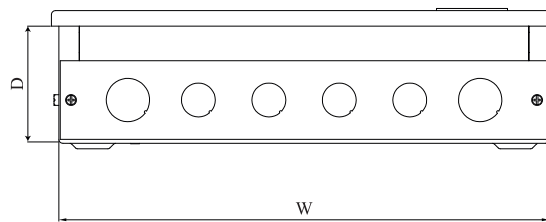
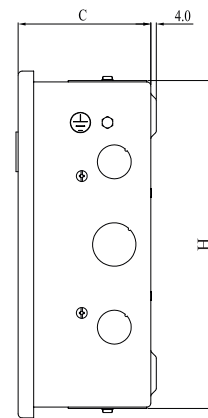
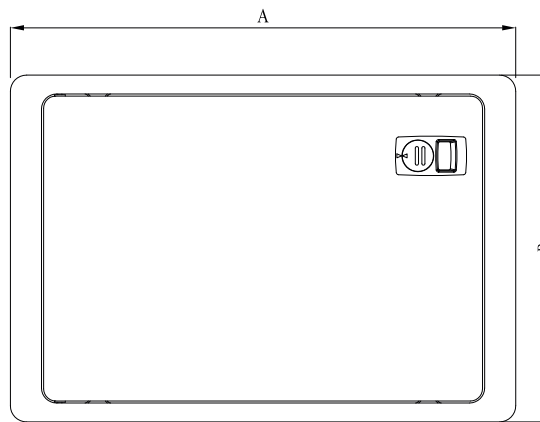
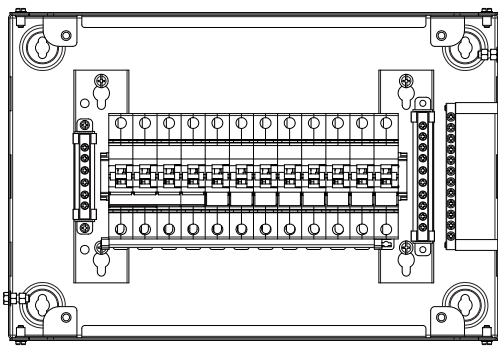

Mounting Hole Details

SINGLE PHASE DISTRIBUTION BOARD WITH DOOR

SL.NO	ITEMS DESCRIPTION	DB OVERALL DIMENSIONS (MM)			BASE OVERALL DIMENSIONS (MM)			MOUNTING HOLE DETAILS		TOP KNOCKOUT	TOP KNOCKOUT	TOP KNOCKOUT	TOP KNOCKOUT
		A	B	C	W	H	D	W	H	25MM	25MM	25MM	25MM
1	4 WAY	305	250	98	265	220	95	205	120	4	4	2	2
2	6 WAY	305	250	98	265	220	95	205	120	4	4	2	2
3	8 WAY	340	250	98	300	220	95	240	120	5	5	2	2
4	12 WAY	410	250	98	370	220	95	310	120	6	6	2	2
5	16 WAY	480	250	98	440	220	95	380	120	8	8	2	2

All dimensions are in mm

TP&N DISTRIBUTION BOARD



NO. OF WAYS	I/C+O/G	CAT NO. (DD)	MRP ₹
4	8+12	LDDB00TPN004WDD	3,890/-
6	8+18	LDDB00TPN006WDD	4,680/-
8	8+24	LDDB00TPN008WDD	5,790/-
12	8+36	LDDB00TPN012WDD	8,680/-

DIMENSIONS

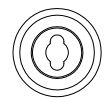
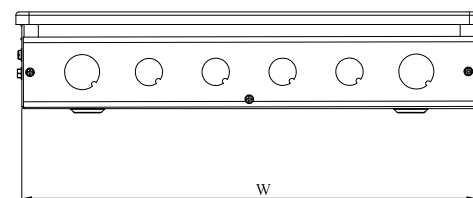
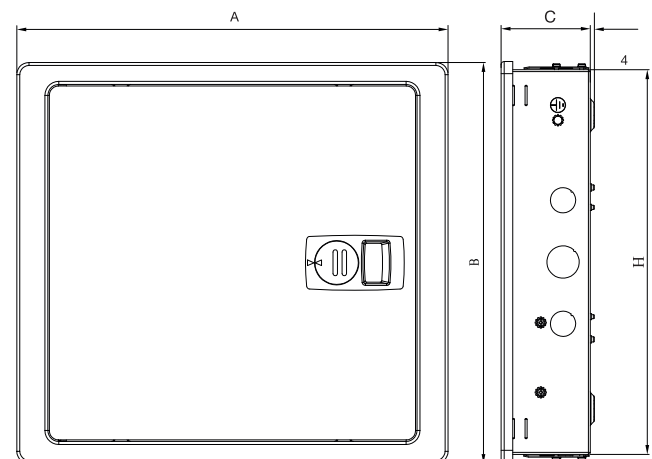
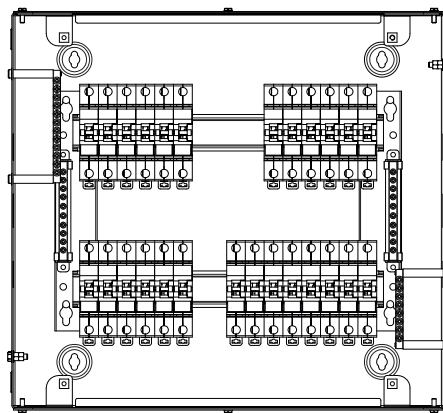

Mounting Hole Details

THREE PHASE DISTRIBUTION BOARD WITH DOOR

SL.NO	ITEMS DESCRIPTION	DB OVERALL DIMENSIONS (MM)			BASE OVERALL DIMENSIONS (MM)			MOUNTING HOLE DETAILS		TOP KNOCKOUT	TOP KNOCKOUT	TOP KNOCKOUT	TOP KNOCKOUT
		A	B	C	W	H	D	W	H	25MM	25MM	25MM	25MM
1	4 WAY	425	410	98	385	380	95	325	280	6	6	3	3
2	6 WAY	460	410	98	420	380	95	360	280	7	7	3	3
3	8 WAY	495	410	98	455	380	95	395	280	8	8	3	3
4	12 WAY	640	410	98	600	380	95	540	280	11	11	3	3

MANUAL PHASE SELECTOR HORIZONTAL DB FITTED WITH 3NOS ROTARY SWITCH



NO. OF WAYS	I/C+O/G	CAT NO. (DD)	MRP ₹
4	63A	LDDB0PH4W0063DD	13,310/-
6	63A	LDDB0PH6W0063DD	13,590/-
8	63A	LDDB0PH8W0063DD	14,590/-
12	63A	LDDB0PH12W0063DD	16,900/-

DIMENSIONS

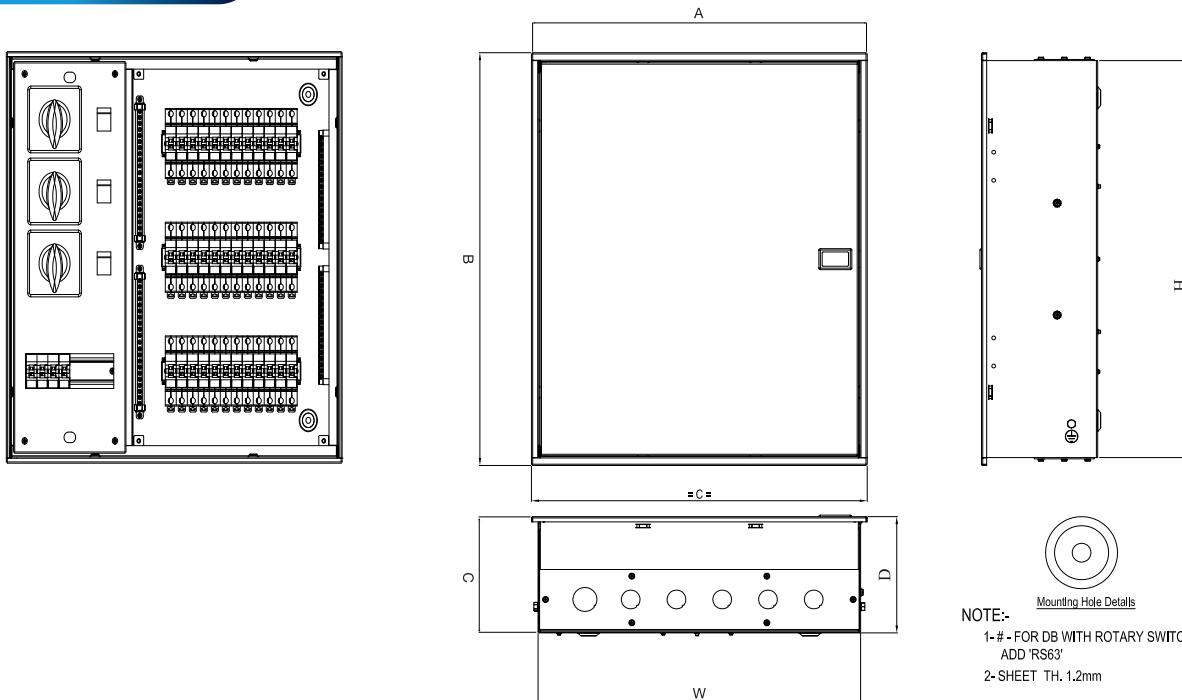

TPN PHASE SELECTOR DISTRIBUTION BOARD WITH DOOR

SL.NO	ITEMS DESCRIPTION	DB OVERALL DIMENSIONS (MM)			BASE OVERALL DIMENSIONS (MM)			MOUNTING HOLE DETAILS		TOP KNOCKOUT	TOP KNOCKOUT	TOP KNOCKOUT	TOP KNOCKOUT
		W	H	D	W	H	D	W	H	25MM	25MM	25MM	25MM
1	4 WAY	470	585	143	430	555	140	330	455	7	7	3	3
2	6 WAY	470	585	143	430	555	140	330	455	7	7	3	3
3	8 WAY	505	585	143	465	555	140	365	455	8	8	3	3
4	12 WAY	575	585	143	535	555	140	135	455	9	9	3	3

All dimensions are in mm



LUKER ELECTRIC TECHNOLOGIES PVT. LTD.

- Regd. Office** : 34/1912-C1, Mattathil Lane, BTS Road, Kochi-682024, Ernakulam, Kerala
- Corp. Office** : 2nd Floor, Jain Tower, NH-17 Bypass, Opp. Lulu Mall, Edappally, Kochi-682 024,
Ph: +91-8129333131, 9746497564, 9895011400, Email: sales@lukerindia.com
- Factory** : 227, Pollachi Road, Eachanari Village, Coimbatore - 641 02, Ph: +91 9994433151,
+91 9447140720
- Tamil Nadu** : Coimbatore: No.22, A.T.T. Colony, First Floor, A.V. Centre, V.O.C. Park Road,
Coimbatore-641018, Ph: 0422 2309977, 9994481477

Chennai : No. 11/6, Damodaran Street, Chetpet, Chennai-600031, Ph: +91 9994422007
- Karnataka** : #1583, 13th Main, 20th Cross, B-Block, Sahakar Nagar, Bangalore-560092, Ph: 9739677890
- Hyderabad** : Door No.101, First Floor, Abhinandan Apt, Plot No. E32, Vikrampuri Housing Colony,
Secunderabad -500009, Ph: +91 040-27746268, 9866077902, 9866190316,
Email: hyd@lukerindia.com,
- Mumbai** : 1806, Lodha Supremus, Saki Vihar Road, Opp. M.T.N.L. Building,
Andheri (East), Mumbai-400072, Ph: +91 9820009055, +91 9769207676
- Ahmedabad** : G-102, Smarana Bakeri City, Near Torrent Power, Sonal Cinema Road,
Vejalpur, Ahmedabad-380051, Gujarat, Ph: +91 9687300643,
Email: sales@lukerindia.com
- Kolkata** : 7/1 Lord Sinha Road, Lords, Room No. 313, 3rd floor, Kolkata-700 071, Ph: 9007277527

Representative offices at : Warangal - 9948546699, Karim Nagar - 8801142143, Kakinada - 9393252573,
Mangalore - 7022119165, Chennai - 9994422007, Salem - 9994447996 / 9994013192, Trichy -
8056180666/8248401759, Pondicherry - 9994491117, Madurai - 7708111815, Pune - 9890696933, Nagpur -
7774038283, Nasik - 7769091911, Baroda - 9687300643, Raipur - 7774038283, Bhopal - 7774038283,
Vijayawada - 9553770189, Visakhapatnam - 9246999368, Goa - 9158159062, Indore - 9329754005, Surat -
9825506072, Rajkot - 9825506072, Jabalpur - 9329754005, Gwalior - 9329754005, Eluru - 7306613030

Luker Electric Technologies Inc.

1 Cragwood RD STE 103A, S Plainfield, NJ 07080, U S A, Ph: +1 (914) 573-1616

www.lukerus.com

Luker Inc.
Dean Park Road,
Scarpoorough,
Toronto, Canada

Luker Inc.
25, Bon Church Road
ELM Grove
Brighton, United Kingdom

Luker Inc.
9 Ivy Court,
Cranbourne North
Victoria 3977, Melbourne

Luker Electric Tech. LLC
173, Road 1111/311
Manama, P.O. Box 1049
Kingdom of Bahrain

Consumer Care No.: 1800 120 2350